

# CLT IMPACT TOOL

## USER GUIDE

HELPING COMMUNITY LED  
AND COLLABORATIVE HOUSING  
GROUPS TO DEMONSTRATE  
THE BENEFITS THEY BRING



This tool was created thanks to funding from the EU's Interreg North-West Europe Sustainable Housing for Inclusive and Cohesive Cities (SHICC) project. This is a partnership between Community Land Trust Bruxelles, National Community Land Trust Network, vzw Samenlevingsopbouw Gent, London Community Land Trust and Fonds Mondial pour le Développement des Villes (FMDV).

All of these partners participated in workshops and consultation run by the TI Group to develop, based on their ideas and experience, the impact themes used in this tool.



Design by [www.noble.studio](http://www.noble.studio)

This tool is licensed under CC BY-SA 4.0



# INTRODUCTION

This tool will help you to start thinking about the impact of your Community Land Trust (CLT) or community housing project and how you can measure this impact. At the end of using the tool you will have:

- an understanding of your impact focus
- an assessment of the quality of your measures
- a plan of how to improve the quality if needed.

This will be in order to have robust information and evidence that will help you:

- make better decisions
- solve problems strategically and tactically
- create persuasive and compelling communications.

It is also hoped that the demonstrated success of your CLT could help other CLT's and community housing projects in the future.

**A thorough run-through of the tool could take as much as half a day. It's worth allowing time for a good discussion. If you have less time, choose less Impact Statements in PART 1 step 9 to work on. You could even split the work over a few sessions.**

# GETTING STARTED

Please go to <https://forms.gle/YHLQDwBsBRqx1gBJ8>

This is a link to a survey that will help us know who is using the tool.  
It will be useful to have this open as you go through the user guide.

## YOU WILL NEED:

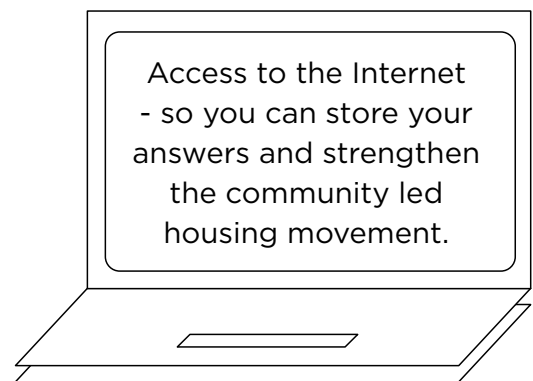
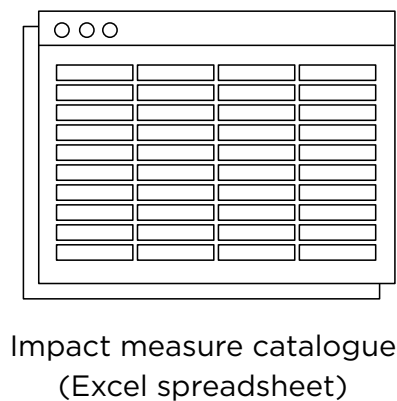
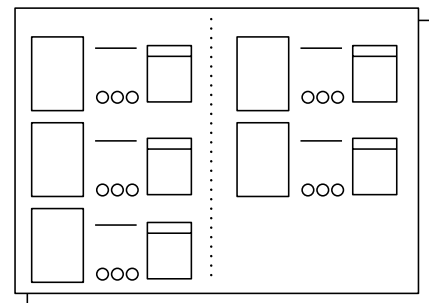
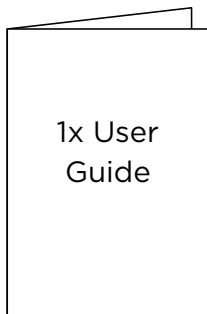

# PART I - IMPACT FOCUS

The impact themes were developed and chosen based on what the project partners saw as important to CLTs and community housing. (Please see appendix for more detail.) Different partners saw these impact themes as more or less important depending on their context. This means that groups using this tool are likely to have different results: they might be very focused on one theme, or spread across several, or even all five of the impact themes. There was general agreement that mature groups or organisations would probably be working across several impact themes.



With this in mind, groups using the tool might want to ask themselves “do we have a good balance of breadth and depth for where we are now?” Groups should be able to see how it was in the past, based on the evidence, and may also want to ask themselves “how might our impact themes change in the next stage of our life?”.



1. Take the set of Impact Statements and as a group consider the question:

2. Make three piles, allocating each Impact Statement to one of the piles:

**“Is this an impact focus for our community housing project?”**

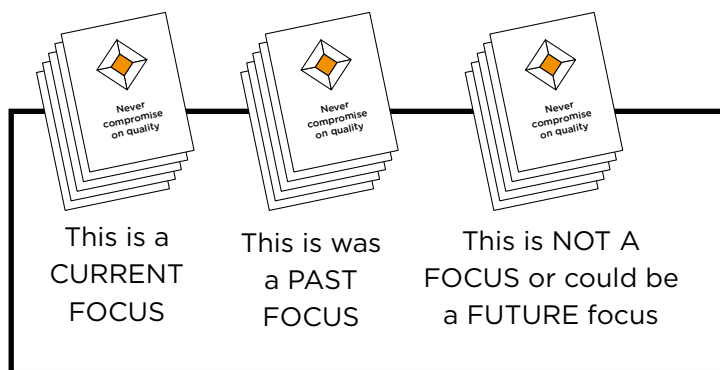

3. Lay out all the statements from the CURRENT FOCUS pile, put them in theme (colour groups) and photograph this. Add the label card or a label on a sticky note or piece of paper so you know which group they are in.

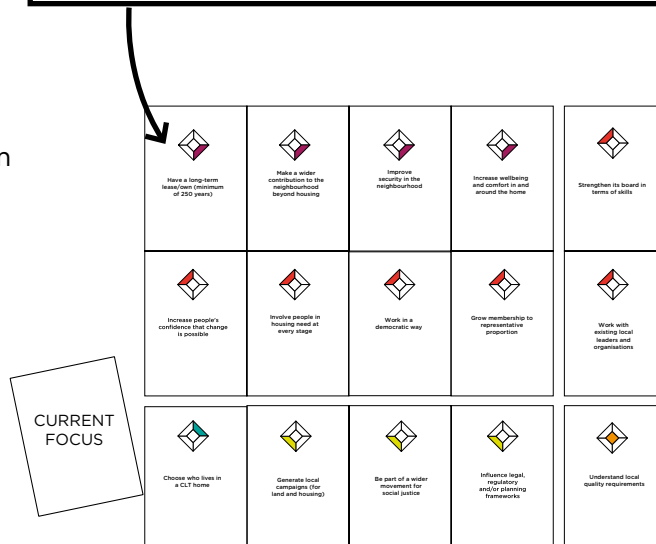

4. Count how many Impact Statements you have and fill out the diagram below with how many cards you have for each theme, and how many in total. Please select the impact focus that seems most important to you now on the survey (Part I - Current Impact Focus).

5. Repeat steps 3 and 4 with the PAST FOCUS cards. For the NOT A FOCUS or could be a FUTURE focus, just do step 3.

6. After photographing it, you can discard the NOT A FOCUS or could be a FUTURE focus pile.

Write number here

## IMPACT FOCUS OVERVIEW

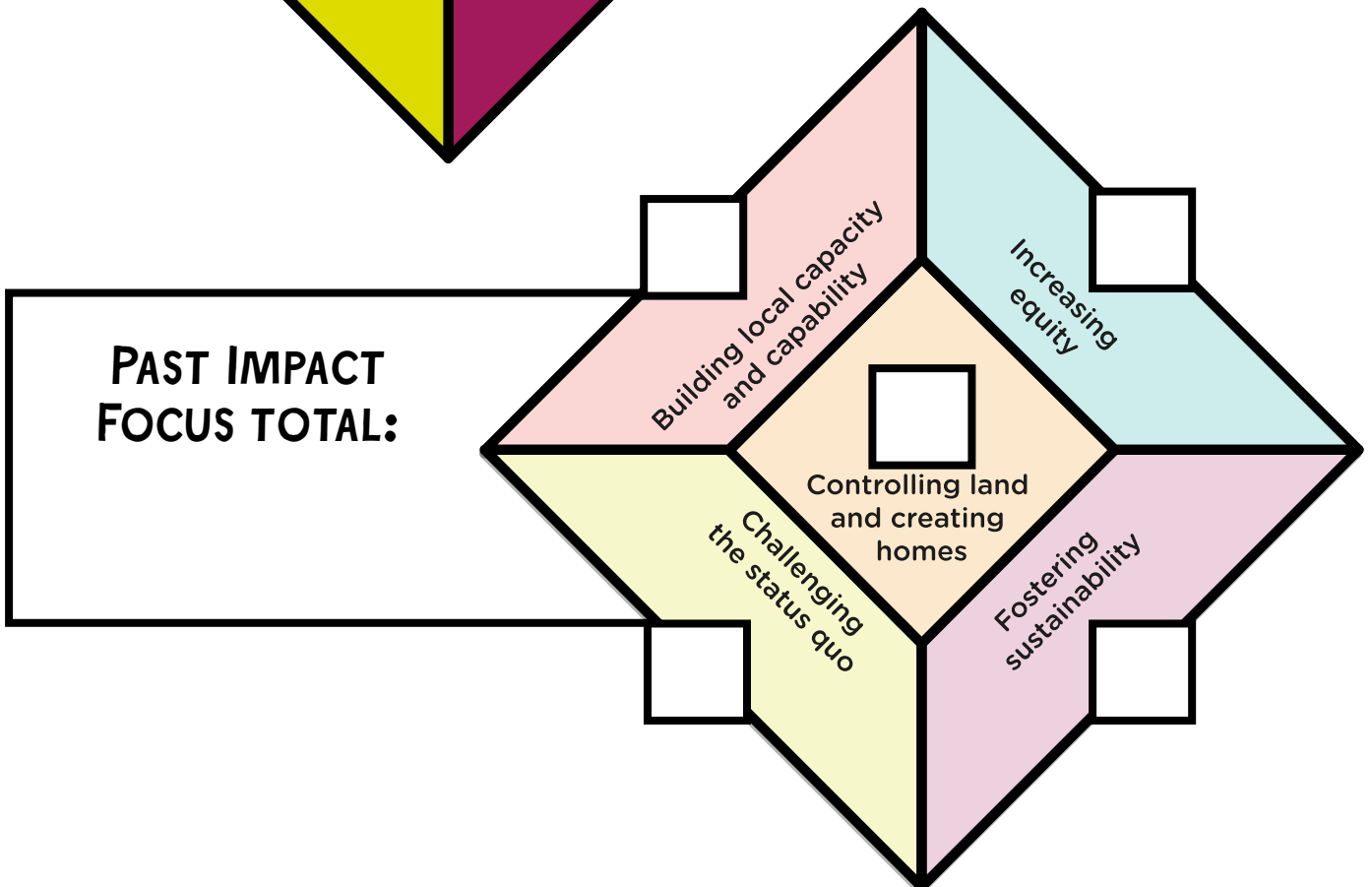
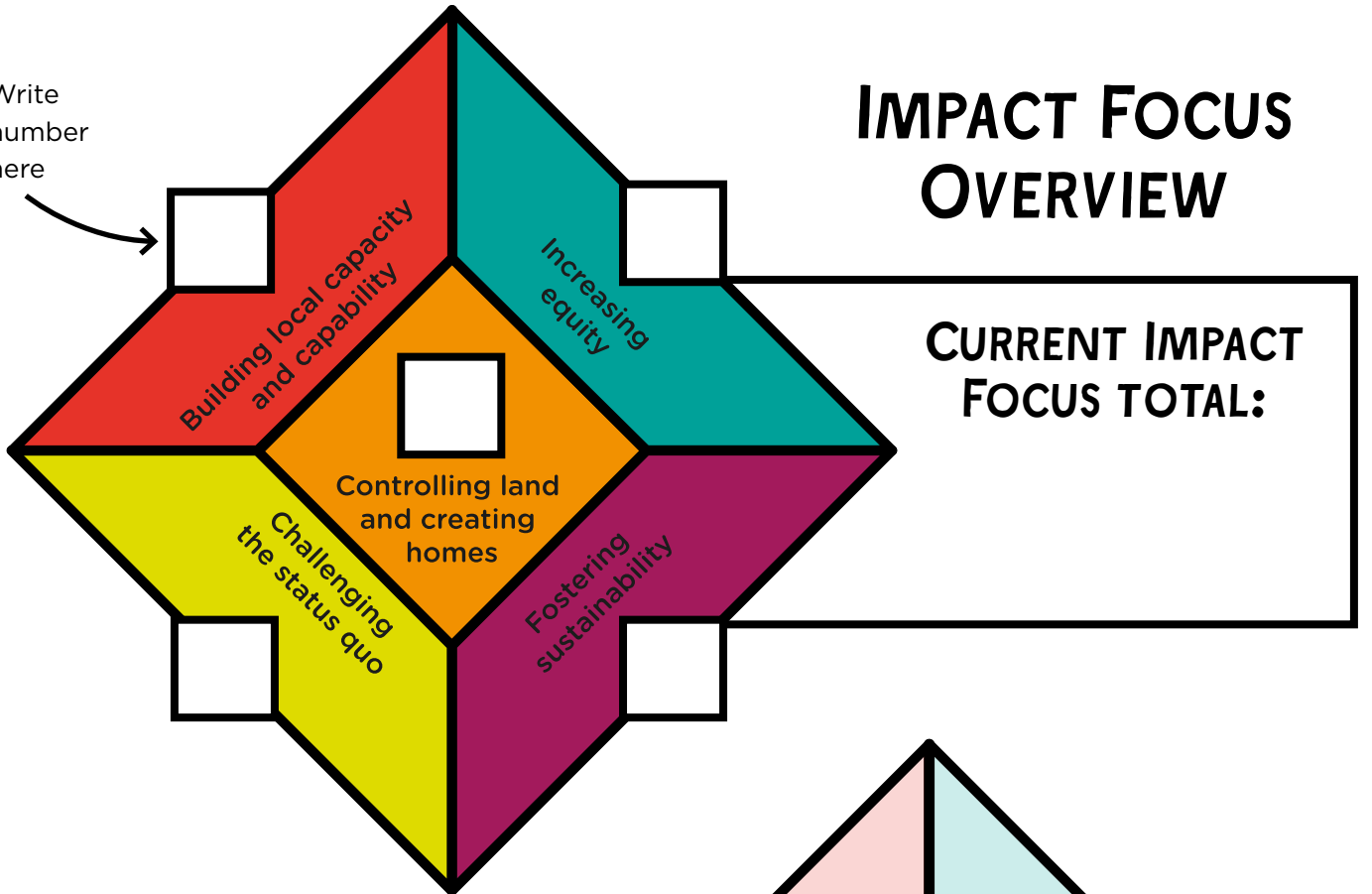

7. As a group have a look at the CURRENT and PAST FOCUS piles. Consider the following questions and spend 5 minutes in discussion:

What is the distribution amongst the themes? Is there a range or more of a concentration on one or two themes??

Why might you have a particular distribution or concentration? Is it your stage in your lifecycle or is it because of your stakeholders?

How might the impact focus change over the lifecycle of the project? Do we need to get ready for new impact themes or measures that we haven't focused on before?

8. Start with your current impact focus. Choose the theme(s) that seem particularly significant. You might want to focus on one, because that is appropriate for you now, but remember that over time you probably want to work on a mix of impact themes.

9. Look back at the statement cards you picked under this theme (or themes). You now need to prioritise some statement cards. This will help you spend your time on what it is most important to measure. Pick the top three (or five) that you feel are most important or significant for your group. Put them on the Impact Evidence Sheet and please select the most important statements on the survey.

If you are really short of time, choose one that feels important, and organise one or two follow up meetings for the others that are important to measure.

10. Repeat steps 8 and 9 for the PAST FOCUS cards and put them on the other Impact Evidence Sheet. Please add them to the survey, choosing the most important impact focus and the statements within it that seemed most important.

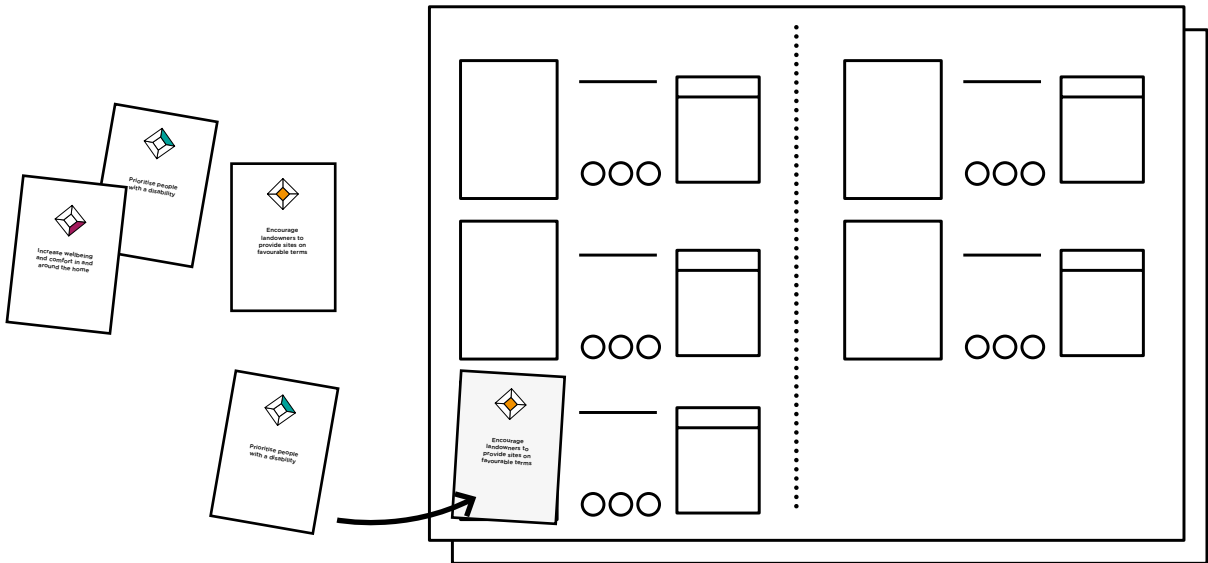

# PART 2 - QUALITY OF YOUR EVIDENCE

Good measures of impact give the information and evidence needed in order to:

## Help with decision making.

Good measures can help you decide where to improve, where to change direction and when to keep going.

## Remove barriers to progress or solve problems.

Evidence of your success or other similar projects may persuade key stakeholders to join you or use their power and influence to help you.

## Create compelling and persuasive communications

that may attract funding, media coverage to raise your profile or new members to your project.

1. Look at the Impact Evidence Sheet and have the Impact Measure Catalogue to hand. For each of your Impact Statements consider the following:

- If this is an Impact Statement from your PAST FOCUS pile and you consider this to be something done or achieved, what evidence do you have to demonstrate this?
- If this is a CURRENT FOCUS are you measuring this? What is the measure?
- Are you already collecting information or data that might help you measure this?
- Could you use one of the measures from the Impact Measure Catalogue? Or does this give you an idea of another measure you could create?

2. Discuss the options as a group. Once you have decided on the measure write it on the Impact Evidence Sheet next to the Impact Statement.

3. Thinking about the measure chosen, consider the quality of the measure or the evidence you have to support this Impact Statement. Using the following rating, decide if your measure is Red, Amber or Green.

 Green - good evidence of impact - your own data, reports and information demonstrate the impact you are having.

 Amber - adequate evidence of impact - you have some data, or could easily get the data that supports your measure, or you know of another similar CLT that has data that could help demonstrate your intended impact.

 Red - poor evidence of impact - you can't find a suitable measure or other evidence, or you don't have the means to get it, and/or you don't know of anyone else that might have useful, relevant information.

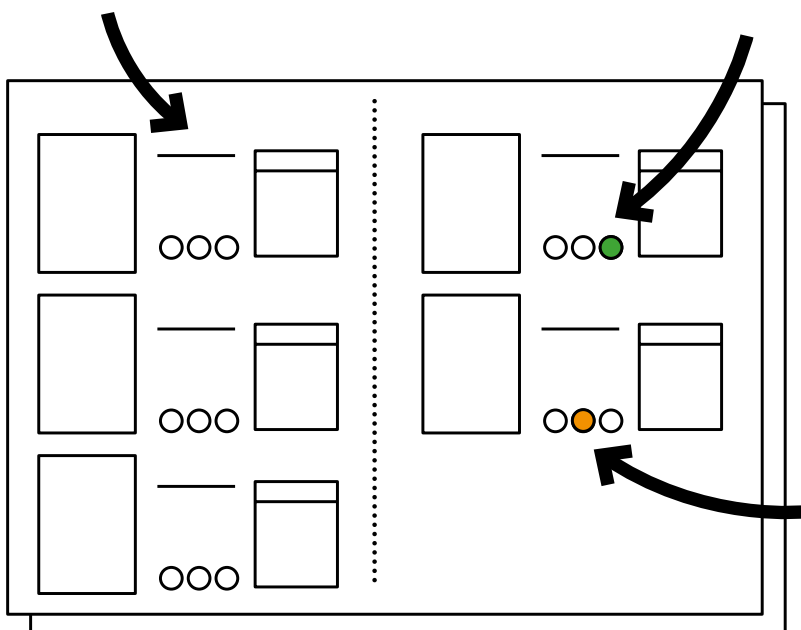

The diagram illustrates the layout of an Impact Evidence Sheet. It consists of a grid of boxes. On the left side, there are three rows of boxes, each containing a large empty box for an impact statement, a horizontal line for a measure, and a smaller box for evidence. To the right of each row are three small circles representing a rating. A vertical dotted line separates the left and right sides of the sheet. On the right side, there are three rows of boxes, each containing a large empty box for an impact statement, a horizontal line for a measure, and a smaller box for evidence. To the right of each row are three small circles representing a rating. Arrows point to specific cells: one arrow points to the top-left cell, another points to the top-right cell (where the top-right circle is green), and a third points to the bottom-right cell (where the bottom-right circle is amber).

4. If you have any amber ratings discuss what you need to do to improve the quality of the measure. Write who will do what by when in the notes section of the Impact Statement. If you have any red ratings make a note of who you will contact and by when to get advice on the measure.

5. Please take a photo of your impact evidence sheets and upload them to the survey (Part II - Quality of your evidence).



# PART 3 – HOW CAN YOU USE YOUR EVIDENCE TO HELP YOU?

1. What are your current, most pressing needs? You could do this individually first, then share these ideas as a group. For example:

- Do you have a current roadblock? Perhaps lack of funding, a hostile decision maker, or lack of consensus?
- Do you need to gather support?
- Do you have to find collaborators?



2. Decide on your top three needs.

3. How could thinking about these needs with an impact lens help you move these forward?

- A. Do you need others to get on board and help you? Would evidence of your impact and value persuade them to help you?
- B. Are you applying for funding? Will your or others evidence help you?
- C. Are you trying to decide where to allocate your resources? Which desired impact is the most important to you and does it need funding?



If you need a better understanding of your stakeholders and what might be important to them, try doing a stakeholder analysis and a bit of research. It might be worth finding out where your impact priorities might be aligned.

<https://www.thegrassrootscollective.org/stakeholder-analysis-nonprofit>



If you need to work on communicating and telling better stories about your project, you could look at to give you a few tips and tricks.

<https://knowhow.ncvo.org.uk/how-to/how-to-tell-your-impact-story>



# PART 4 – NEXT STEPS

1. Think about how confident you'd feel about measurement if you put all this into practice. And tell us what you thought using the survey. (Your feedback helps us to help the community led housing movement.)
2. Start using the evidence you have to help you keep going - the green rated statements and evidence are ready to go.
3. Make sure you have a plan of action for your amber measures. Set a short deadline and make sure everyone knows whose responsibility it is.
4. Seek advice on your red impact areas. Ask for recommendations of measures or evidence and examples from other community housing projects who do have evidence from this impact area.
5. Repeat this again when your project moves on and you have a new focus or roadblock. As a suggestion, you might want to re-run this in a year's time.



# APPENDIX: ABOUT THE IMPACT THEMES

The five impact themes used in this tool were developed through a process of participation between the SHICC partners with support from the TI Group. This included workshops, visits, interviews and rounds of comments.

The hypothesis was that although communities and contexts can be very different, CLTs and other community housing groups have characteristics in common. The aim was to find some common characteristics related to the impact groups want to have. These became the impact themes.

The first hope is that these impact themes will help groups think about their priorities and distinctive mission within a common framework. The second hope is that this common framework is a useful tool for learning, thinking and conversations within community housing groups, between them, and with organisations that want to support them.

Based on the understanding of the SHICC partners and the TI group, we think that:

- It would be very surprising if none of the impact themes were relevant to community housing groups!
- Not all impact themes will be equally relevant to all groups
- The relevance of impact themes may change over time for a particular group
- A mature community housing group is likely to want and need to address several of these themes to have a positive impact.

The impact themes are explained below:

## CONTROLLING LAND AND CREATING HOMES

Progress in acquiring land, houses, or other assets, is an important way of describing the impact of CLTs and community housing groups. CLTs are a tangible solution not an abstract one! Impact has a physical form in land and buildings that the CLT or community housing group controls.

## BUILDING LOCAL CAPACITY AND CAPABILITY

CLTs and community housing groups should have high and increasing levels of local ownership and management. Ideally, local people experience a greater sense of personal agency and empowerment. They may channel this into campaigning locally or more widely.

## INCREASING EQUITY

CLTs and community housing rebalance local housing provision to enable access for people who would otherwise struggle to find stable and suitable homes. This has broader positive effects in the lives of residents and their families, including their ability to participate in civic life. It can also have an effect on their wider communities. Impact looks like greater equity and equality.

## CHALLENGING THE STATUS QUO

CLTs and community housing engage with the dynamics of housing in their areas and potentially beyond, to challenge the status quo. This can be by demonstrating better ways of creating housing with and for communities as well as organising or influencing policy. Groups may seek to have a disruptive, systemic impact.

## FOSTERING SUSTAINABILITY

CLTs are a durable solution and think long term, capturing and protecting wealth for multiple generations. This works at many levels, such as the homes themselves, the organisation, the local area and the environment. Healthy CLTs have democratic membership that represents the diversity of their communities. CLTs consider absent voices and future generations.

